

MYDEX Application Detail Data Sheets

Company name	
Department	
Contact name	
Phone	
Fax.	
E-mail address	

Date

Tsubaki Yamakyu Chain Co.,Ltd.

TEL. (03)-3445-8597

FAX. (03)-3440-1285

E-mail Address:mydex-e@tsubakiyamakyu.co.jp

Dial Plate Application	
1.Number of stops :	
2.Cam index angle :	
3.Cycle time :	Index time (s)+ Dwell time (s)= Total time
4.Rotation speed of input :	
5.Cam motion law :	<input type="checkbox"/> Standard <input type="checkbox"/> Special (Constant , Synchronism)
6.Conveyor drive method :	<input type="checkbox"/> Direct drive <input type="checkbox"/> Indirect
7.Dial plate :	Dw= mm Weight:Wt= Kg
8.Parts conveyed :	Pitch circle diameter : Dpw= mm Weight:Wa= Kg/p.c.s.Quantity: p.c.s
9.Weight of parts :	Weight : Wp= Kg/p.c.s.Quantity: p.c.s.
10.Friction torque :	<input type="checkbox"/> Yes <input type="checkbox"/> No R= mm Coefficient of friction (μ)=
11.External loads during the Index period(time) :	<input type="checkbox"/> Yes <input type="checkbox"/> No R= mm P= N
14.Expected life :	
15.Number of stop ratio :	Number of stops in one revolution of the indexer : Number of stops in one revolution of the indexed sprocket

Direct Drive

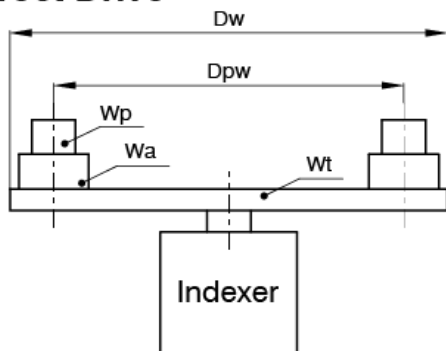

Indirect Drive

